



SEWER & STORMWATER PIPE CLEANING TOOLS
VERSION 8

www.reddawgnozzles.com

THE RED DAWG MANIFESTO

We believe that our small team is capable of great things. Our focus is to create reliable, high-performing tools that outlast expectations. We know that operators don't need to spend tons of money to get great tools for their jetting equipment. Hard working Texans design, test and develop these tools and refuse to accept that all good ideas relating to sewer cleaning tools come from across the pond.

WHAT MAKES RED DAWG DIFFERENT

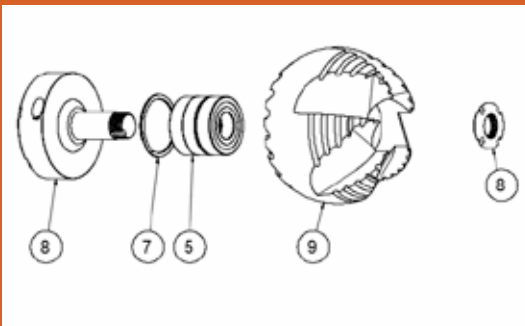

DESIGNED, BUILT AND TESTED HERE IN TEXAS

The red dawg team is a small group that is passionate about getting more from your jetter. We spend weeks developing tools investing in all material and design possibilities before it sees the light of day.



ENHANCED STREAM TECHNOLOGY INSERTS (EST)

After surveying the industry, we found a design that worked far better than the rest. This is what we used in our highest performance nozzles. The result is a focused stream that can't be beat. The benefit is very powerful cleaning potential with less water.



5TH AXIS MACHINING PRECISION

We use the latest in 5th axis machining technology. This allows for less setups and more accurate and consistent parts. It also helps us keep our cost down on nozzles across the board.

TABLE OF CONTENTS

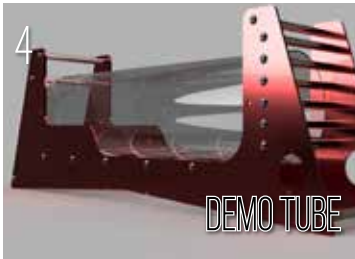

4 DEMO TUBE

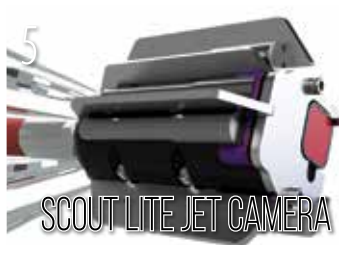

5 SCOUT LITE JET CAMERA



6 SCOUT JET CAMERA



7 SCOUT JET CAMERA



8 ROOT DAWG NOZZLE

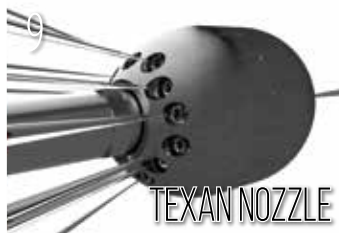

9 TEXAN NOZZLE



10 BABY TEXAN NOZZLE



11 BARRICADE NOZZLE



12 HULI-HULI NOZZLE



13 TITAN TORRENT



14 BLOODHOUND MINI NOZZLE



15 HERO NOZZLE



16 10-JET NOZZLE



17 MUD DAWG NOZZLES

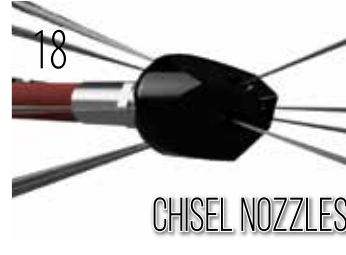

18 CHISEL NOZZLES



19 SAND HOG NOZZLES



20 HOT DAWG NOZZLES



21 BULKHEAD NOZZLES



22 TRIPLE TAP NOZZLES



23 LOW PRO NOZZLES



24 BUTTON NOZZLES



25 ALUM. SAND NOZZLE



26 KRAKEN ROOT CUTTER



27



28 HOSE PROTECTION & ACC.



29 HOSE ENDS & FITTINGS



30 HYDRO-X TIPS



31

SWIVELS AND SKIDS

DEMO/TEST TUBE

TESTING AND EVALUATION

TECHNICAL INFO

- 3007-301 SERIES
- LASER-CUT ALUMINUM
- SOLID THREADED ALUMINUM STRUCTURAL POST
- STAINLESS STEEL HARDWARE
- OPTIONAL FLOW METER
- OPTIONAL THRUST METER
- OPTIONAL PRESSURE GAUGE



SAFELY TEST AND DEMONSTRATE ANY NOZZLE WITH THIS SETUP. MADE FOR OPERATION ON THE GROUND OR HITCH MOUNTED. THE CLEAR LEXAN PROVIDES A SAFE BARRIER BETWEEN HIGH-PRESSURE JETS AND YOUR EYEBALLS. SAFELY EVALUATE AND INSPECT YOUR NOZZLE'S JET PATTERN WITH THIS SETUP. LOTS OF OPTIONAL EQUIPMENT TO DIAL IT IN AS NEEDED. ADD THE FOLLOWING AS OPTIONS: FLOW METER, THRUST GAUGE, PRESSURE GAUGE.

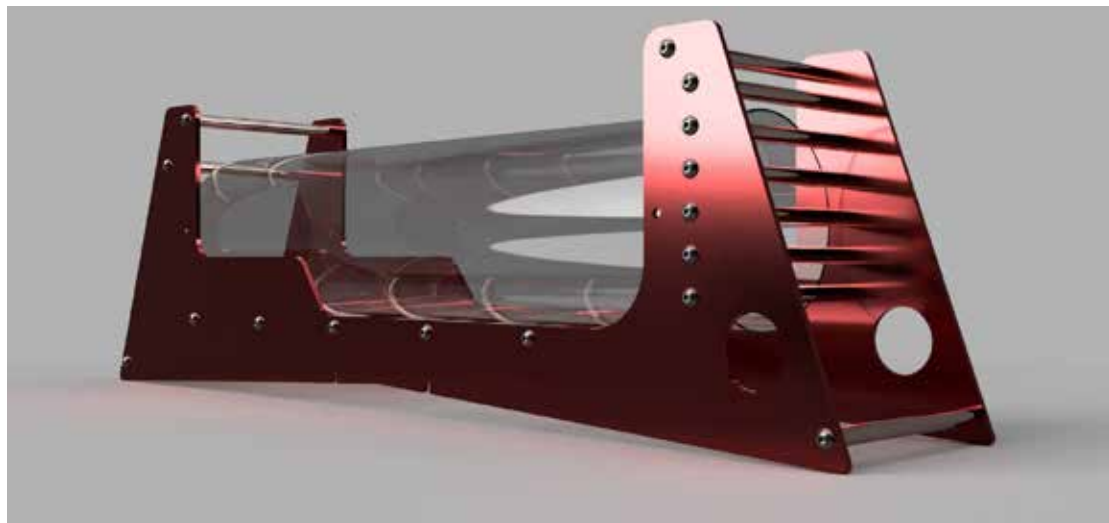



SCOUT-LITE JET CAMERA

6"-12" LINE CAMERA

TECHNICAL INFO

3007-102L SERIES

BILLET ANODIZED ALUMINUM BODY

1/16" NPT REAR INSERTS (X6) @ 15 DEG.

REPLACEABLE FIN SKID PLATES

LED PEN LIGHTING

ACTION CAMERA COMPATIBLE

EST COMPATIBLE INSERT UPGRADE

OPTIONAL WHEELED FIN SKID SHOWN IN SOME
PICS BELOW (P/N: 3007-102.9WK12)

OVERVIEW

THE RED DAWG SCOUT LITE OFFERS AFFORDABLE AND SIMPLIFIED ACCESS INTO MOST SEWER AND STORM LINES BETWEEN 6" AND 15". THE SCOUT-LITE IS AVAILABLE FOR BOTH 1/2" AND 3/4" SYSTEMS. THREE WATER-PROOF LED FLASHLIGHTS OFFER A SIMPLE LIGHT SOURCE FOR THE CAMERA AND THREE AAA BATTERIES CAN BE CHANGED HASTLE-FREE. A DURABLE SPORTS ACTION CAMERA IS EMBEDDED INSIDE THE ALUMINUM BODY WHICH PROTECTS AND CENTERS THE CAMERA. THE SPORTS ACTION CAMERA IS IMPACT RESISTANT AND WATERPROOF MAKING IT THE IDEAL CAMERA FOR SEWER ENVIRONMENT.

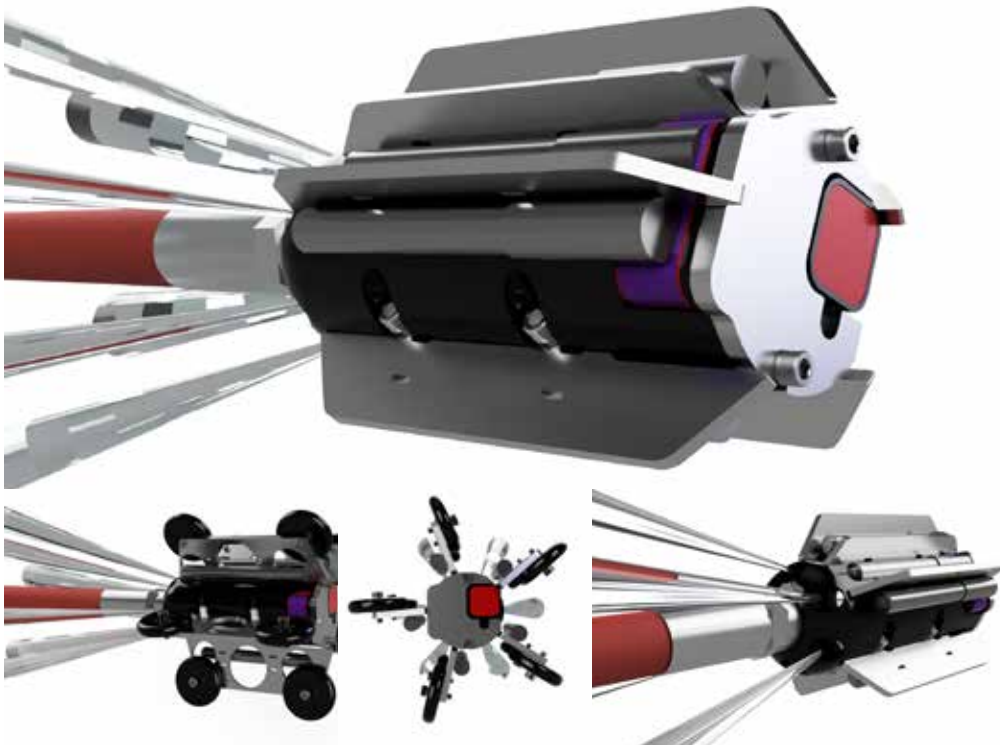

SCOUT JET CAMERA

EVALUATION
MAINLINE INSPECTION
GENERAL CLEANING

TECHNICAL INFO

102.9KIT SERIES

ALUMINUM BODY CONSTRUCTION
15 DEG. REAR 1/8" FNPT PORTS (X6)
1" FNPT INLET PORT
4" O.D. X 8" L
7# WEIGHT
30-85 GPM FLOW RANGE

INCLUDED IN SCOUT KIT:
SCOUT BODY
WATERPROOF, DURABLE CASE
(2) SD CARDS
(2) SPORTS ACTION CAMERAS
CHARGING CABLES
(2) SETS OF FIN SKIDS
3/16" ALLEN TOOL
SCOUT MANUAL

INSERTS FOR SEWER JETTERS 40-80 GPM

**REPLACEABLE REAR INSERTS
TO CONFIGURE TO YOUR WATER SYSTEM**

**CHANGEABLE FIN PLATES TO
ADAPT TO DIFFERENT SIZE PIPES**

**CHANGEABLE FIN PLATE
ADAPT TO DIFFERENT SIZE**

**RECHARGEABLE INTERNAL
BATTERY FOR 8 HOURS OF USE**

**EMBEDDED LED RING TO
LIGHT UP DARK LINES**

**INTEGRATED CAMERA POCKET
TO PROTECT YOUR GOPRO**

**ES TO
PIPES**

ROOT DAWG NOZZLE

MAINLINE
WASTEWATER
STORMATER
STOPPAGES

TECHNICAL INFO

3007-176 SERIES

STAINLESS STEEL & DELRIN BODY
RIPSAW FRONT JET
15 DEG. REAR M6 PORTS (X8)
1" FNPT INLET PORT
3" O.D. X 6" L
3# WEIGHT
25-85 GPM FLOW RANGE



OVERVIEW

A NEW REVISION GIVES THIS NOZZLE NEW LIFE. THIS IS A GREAT TOOL FOR ALL PURPOSES, GENERAL CLEANING, STOPPAGES (GREASE & ROOTS). THE SIX-REAR 30-DEGREE (EIGHT REAR-JETS FOR 1" BODY) PROVIDE THRUST AND PIPE WALL SCOURING FORCE TO PROPEL THIS NOZZLE UP THE LINE. THE REAR MAGIC IS THE ROTATING FRONT JET. AT ABOUT 1,000 PSI THE INSERT BEGINS TO ROTATE AND BREAK UP ANYTHING IN ITS PATH. WHILE PRODUCING A VICIOUS FORCE GOING FORWARD IT ALSO MAINTAINS THE ABILITY TO NOT DAMAGE THE SEWER LINE (ANY MATERIAL). A VIDEO DOES NOT CONVEY THE FORCE THAT THIS NOZZLE PRODUCES GOING FORWARD. THE ROTATING FRONT TIP IS FIELD REBUILDABLE WHEN NEEDED WITH SIMPLE PART REPLACEMENT.



TEXAN NOZZLE

MAINLINE
SANITARY
STORMWATER
PRODUCTION CLEANING



OVERVIEW

LOOKING FOR THE POWER OF BIG TEX BUT WITH A LITTLE LESS SIZE? OUR TEXAN AND TEXAN-LITE FIT THE MOLD! THE TEXAN NOZZLE IS STAINLESS STEEL AND FEATURES THE SAME 12-JET PATTERN OF BIG TEX. THE TEXAN-LITE DOES AS WELL, BUT IS MADE WITH ALUMINIUM WHICH WILL BE GREAT FOR LONG RUNS OR STEEP GRADES. THESE TIER 4 NOZZLES INCLUDE THE BEST TECHNOLOGY IN FLOW DYNAMICS AS WELL AS ENHANCE STREAM TECHNOLOGY.

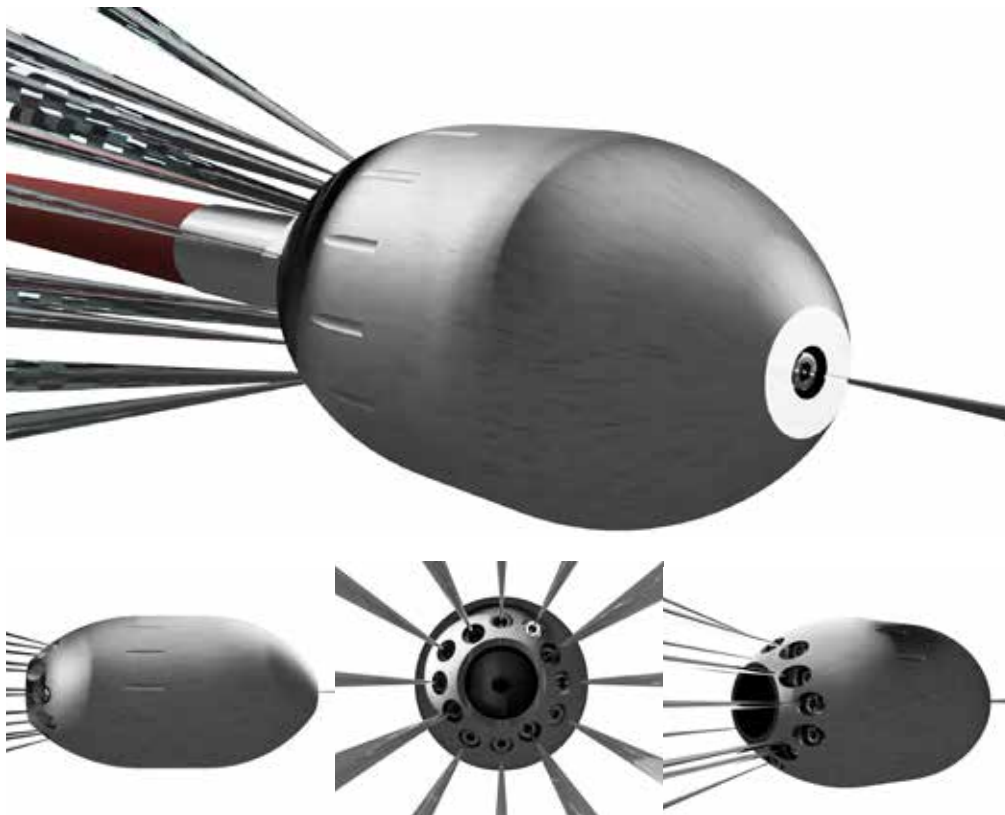

TECHNICAL INFO

3007-111ST SERIES

1-PIECE 304 SS BODY CONSTRUCTION
EST INSERTS ONLY
0 DEG. FRONT 1/8" FNPT PORT
4 X 7 DEG. REAR 1/8" FNPT PORT
4 X 15 DEG. REAR 1/8" FNPT PORT
4 X 20 DEG. REAR 1/8" FNPT PORT
1" FNPT INLET PORT
4.25" O.D. X 7" L
22.5# WEIGHT
80-100 GPM FLOW RANGE

3007-111ST-ALUM SERIES

1-PIECE ALUMINIUM BODY CONSTRUCTION
EST INSERTS ONLY
0 DEG. FRONT 1/8" FNPT PORT
4 X 7 DEG. REAR 1/8" FNPT PORT
4 X 15 DEG. REAR 1/8" FNPT PORT
4 X 20 DEG. REAR 1/8" FNPT PORT
1" FNPT INLET PORT
4.25" O.D. X 7" L
5# WEIGHT
40-100 GPM FLOW RANGE

BABY TEXAN NOZZLE

MAINLINE
WASTEWATER
STORMATER
STOPPAGES

TECHNICAL INFO

3007-119 SERIES

STAINLESS STEEL BODY
15 DEG. REAR M6 PORTS (X8)
3/4" FNPT INLET PORT
3" O.D. X 6" L
3# WEIGHT
18-60 GPM FLOW RANGE

3007-120 SERIES

STAINLESS STEEL BODY
15 DEG. REAR M6 PORTS (X8)
1" FNPT INLET PORT
3" O.D. X 6" L
3# WEIGHT
35-85 GPM FLOW RANGE



OVERVIEW

DO YOU HAVE LINES THAT CONSISTENTLY HAVE ISSUES WITH BLOWING UP TOILETS? THEN THIS IS THE NOZZLE FOR YOU. EIGHT FORWARD FACING JETS, ANGLED AT 60 DEGREES, HELP PREVENT THE VENTURI EFFECT. THIS NOZZLE CAN WORK IN LINES UP TO 12" IN DIAMETER WITH THE PROPER SKIDS TO SET IT UP WHERE IT NEEDS TO BE IN THE PIPE. THE FLOW REQUIRED TO RUN THIS NOZZLE IS 60 GPM AT MINIMUM.

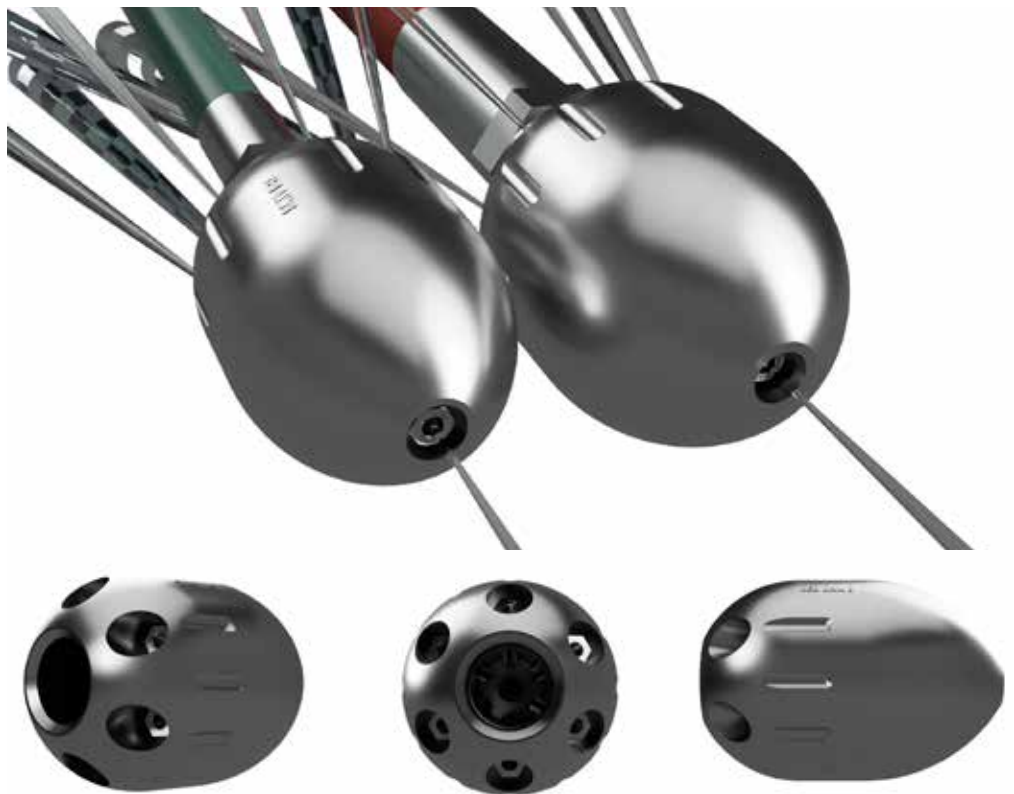

BARRICADE NOZZLE

MAINLINES 6-12"
PRODUCTION CLEANING
NO-BLOW TOILETS
F.O.G. TREATMENT

TECHNICAL INFO

3007-103 SERIES

ANODIZED ALUMINUM BODY
INTERCHANGEABLE SS FIN PLATES
60 DEG. FRONT 1/8" FNPT PORTS (X7)
10 DEG. REAR 1/8" FNPT PORTS (X6)
1" FNPT INLET PORT
4.75" O.D. X 7" L (NO FINIS)
6# WEIGHT
60-85 GPM FLOW RANGE

OVERVIEW

DO YOU HAVE LINES THAT CONSISTENTLY HAVE ISSUES WITH BLOWING UP TOILETS? THEN THIS IS THE NOZZLE FOR YOU. EIGHT FORWARD FACING JETS, ANGLED AT 60 DEGREES, HELP PREVENT THE VENTURI EFFECT. THIS NOZZLE CAN WORK IN LINES UP TO 12" IN DIAMETER WITH THE PROPER SKIDS TO SET IT UP WHERE IT NEEDS TO BE IN THE PIPE. THE FLOW REQUIRED TO RUN THIS NOZZLE IS 60 GPM AT MINIMUM.



HULI-HULI PIPE BALL NOZZLE

LATERALS
CLEANOUTS
GREASE
ROOTS
BUILD UP

TECHNICAL INFO

3007-311 SERIES

SS BODY CONSTRUCTION
X6 15 DEG. REAR JETS 1/16" FNPT PORT
1/2" FNPT INLET PORT
2.95" O.D. X 2.7" L
3# WEIGHT
14-25 GPM FLOW RANGE



OVERVIEW

THE PIPE BALL IS A VERY EFFECTIVE OBSTRUCTION REMOVAL TOOL. IT HAS THE ABILITY TO EAT AWAY AT ALMOST ANYTHING YOU PUT IN FRONT OF IT. DRIVEN BY 3 VANE-DRIVEN INTERIOR JETS, IT SPINS AT HIGH-SPEED TO CARRY AS MUCH ENERGY AS POSSIBLE TO THE CUTTING PROCESS. CUTTING SURFACES ARE KEPT TO THE FRONT TO PREVENT ANY DAMAGE TO PIPE WALLS. THE OPTIONAL TUNGSTEN CARBIDE COATING ADDS LIFE IF USERS REQUIRE IT.

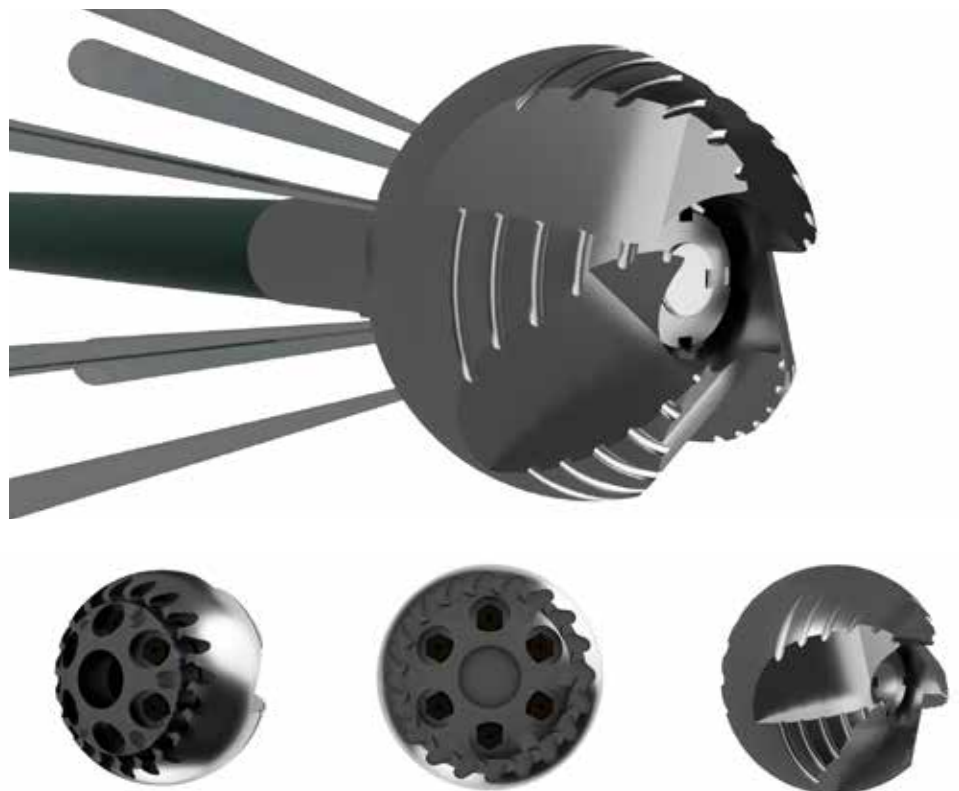



TITAN TORRENT NOZZLE

MAINLINES 6-12"
STOPPAGE RESOLUTION
PRODUCTION CLEANING
F.O.G. TREATMENT

TECHNICAL INFO

3007-254 SERIES (3/4" OR 1" INLET)

STAINLESS STEEL BODY

20 DEG. FRONT JET CONE (X1)

15 DEG. REAR 1/16" FNPT PORTS (X8)

1/2" FNPT INLET PORT

2.5" O.D. X 3.4" L

2# WEIGHT

40-80 GPM FLOW RANGE

OVERVIEW

A NEW REVISION GIVES THIS NOZZLE NEW LIFE. THIS IS A GREAT TOOL FOR ALL PURPOSES, GENERAL CLEANING, STOPPAGES (GREASE & ROOTS). THE SIX-REAR 30-DEGREE (EIGHT REAR-JETS FOR 1" BODY) PROVIDE THRUST AND PIPE WALL SCOURING FORCE TO PROPEL THIS NOZZLE UP THE LINE. THE REAR MAGIC IS THE ROTATING FRONT JET. AT ABOUT 1,000 PSI THE INSERT BEGINS TO ROTATE AND BREAK UP ANYTHING IN ITS PATH. WHILE PRODUCING A VICIOUS FORCE GOING FORWARD IT ALSO MAINTAINS THE ABILITY TO NOT DAMAGE THE SEWER LINE (ANY MATERIAL). A VIDEO DOES NOT CONVEY THE FORCE THAT THIS NOZZLE PRODUCES GOING FORWARD. THE ROTATING FRONT TIP IS FIELD REBUILDABLE WHEN NEEDED WITH SIMPLE PART REPLACEMENT.



BLOODHOUND MINI NOZZLE

LINE LOCATING
PRODUCTION

TECHNICAL INFO

3007-100 SERIES

2-PIECE DESIGN
STAINLESS STEEL & DELRIN BODY CONSTRUCTION
15 DEG. REAR 1/16" FNPT PORTS (X6)
1/2" OR 3/4" FNPT INLET PORT
2.3" O.D. X 7.5" L
2# WEIGHT
14-50 GPM FLOW RANGE

3007-109 SERIES

2-PIECE DESIGN
STAINLESS STEEL & DELRIN BODY CONSTRUCTION
15 DEG. REAR 1/8" FNPT PORTS (X8)
1" OR 3/4" FNPT INLET PORT
3" O.D. X 7" L
4# WEIGHT
35-85 GPM FLOW RANGE



OVERVIEW

IF YOU DON'T HAVE A ONE INCH JETTER BUT STILL NEED TO LOCATE INSIDE A PIPE, THE BLOODHOUND MINI CAN STILL HELP YOU OUT. A LIGHTWEIGHT OUTSIDE CASING WITH SIX REAR JETS ALLOWS YOU TO PLACE THE SONDE YOU ALREADY OWN INSIDE. RUN THE NOZZLE LIKE NORMAL AND FOLLOW WITH ANY LOCATOR.

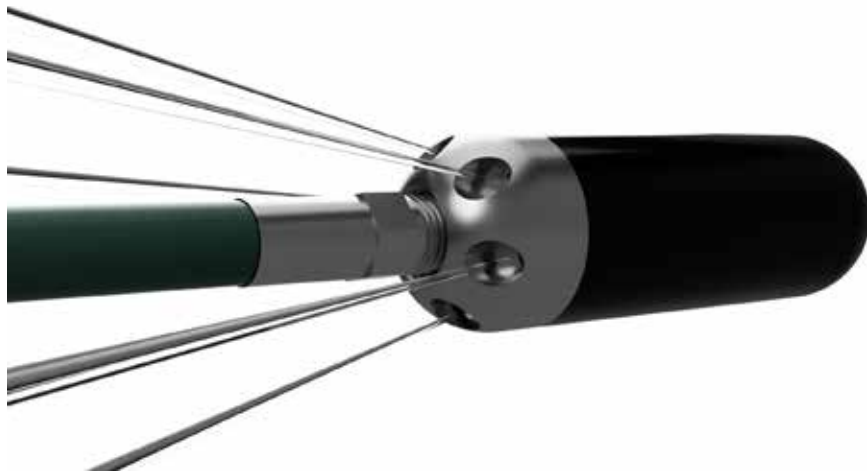

HERO NOZZLE

PRODUCTION
SAND AND GRAVEL
LONG LINES

TECHNICAL INFO

3007-169 SERIES

CARBON STEEL BODY

0 DEG. FRONT 1/16" FNPT PORT

7 DEG. REAR 1/16" FNPT PORTS (X6)

18 DEG. REAR 1/16" FNPT PORTS (X6)

1" FNPT INLET PORT

TIER III INTERNAL PORTING

3" O.D. X 5" L

4.5# WEIGHT

18-85 GPM FLOW RANGE

OVERVIEW

LET THIS BE YOUR EVERYDAY CLEANING NOZZLE. ITS 12 DUAL-ANGLED REAR JETS PROVIDE THRUST AND CLEANING ANGLES TO MAKE THIS A DUAL PURPOSE NOZZLE AS WELL. THE 2.9" DIAMETER BODY PROVIDES A SMALL ENOUGH FOOTPRINT TO WORK IN LINES AS SMALL AS 6", BUT CAN WORK ON JETTERS UP TO 80 GPM. THE TIER III INTERNAL DESIGN WILL MAKE THIS A MUST HAVE FOR OPERATORS CLEANING AHEAD OF A TV CREW OR ACCOMPLISHING PRODUCTION CLEANING WITH MINIMAL WATER USAGE.

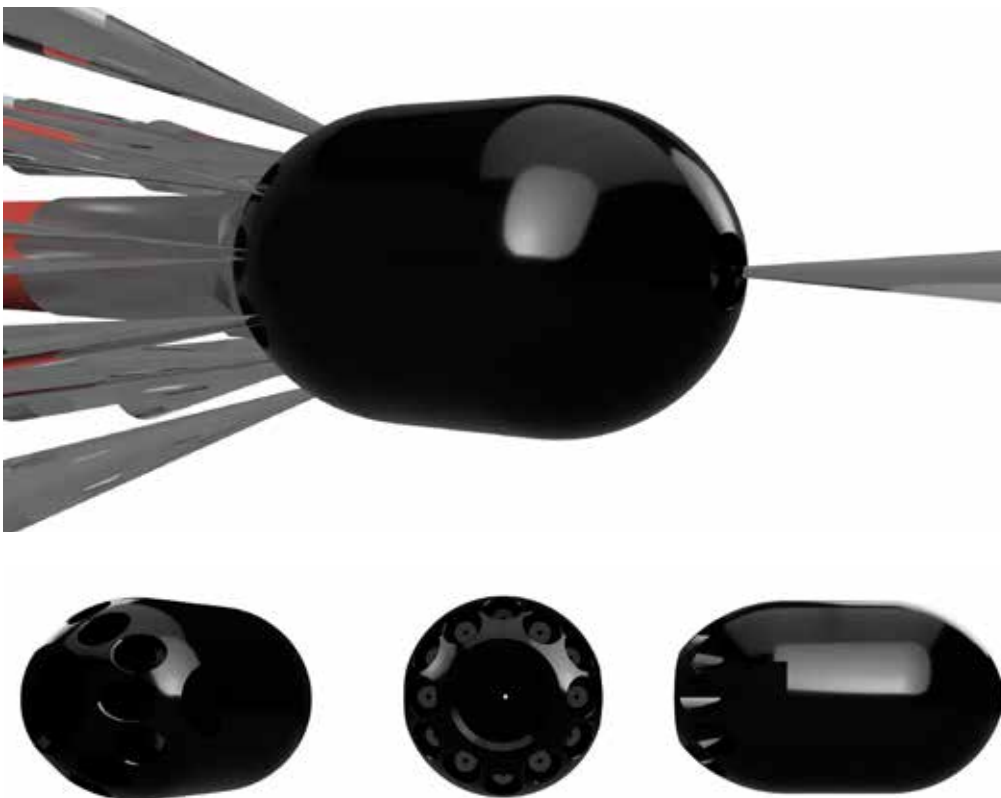

10-JET NOZZLE

MAINLINE
SANITARY
STORMWATER



TECHNICAL INFO

3007-166 SERIES

CARBON STEEL BODY

0 DEG. FRONT 1/16" FNPT PORT

7 DEG. REAR 1/16" FNPT PORTS (X5)

15 DEG. REAR 1/16" FNPT PORTS (X5)

3/4" FNPT INLET PORT

2.3" O.D. X 4" L

TIER III INTERNAL PORTING

1.5# WEIGHT

14-50 GPM FLOW RANGE

3007-159 SERIES

CARBON STEEL BODY

0 DEG. FRONT 1/16" FNPT PORT

7 DEG. REAR 1/16" FNPT PORTS (X5)

15 DEG. REAR 1/16" FNPT PORTS (X5)

1" FNPT INLET PORT

3.5" O.D. X 4" L

TIER III INTERNAL PORTING

14# WEIGHT

40-85 GPM FLOW RANGE

OVERVIEW

HEAVY CLEANING DESIGN FEATURES KEEP THIS NOZZLE WHERE IT NEEDS TO BE. THE REAR FEATURES 10-ALTERNATING ANGLED JETS FOR A MIXED EFFORT OF CLEANING AND THRUST. THIS IS SURE TO BE A STANDARD ISSUE NOZZLE FOR MOST OF THE COMBINATION CLEANERS OUT IN THE FIELD. HEAT TREATED & PLATED TO ENSURE LONG LIFE OUT IN THE FIELD AS WELL. OPTIONAL RETROFITTABLE FIN SKID AVAILABLE (PICTURED BELOW).



MUD DAWG NOZZLE

MAINLINE
SANITARY
STORMWATER
PRODUCTION CLEANING

TECHNICAL INFO

3007-48 SERIES

304 SS BODY CONSTRUCTION
0 DEG. FRONT 1/8" FNPT PORT
1/2" FNPT INLET PORT
1.5" O.D. X 4" L
WEIGHT
14-40 GPM FLOW RANGE

3007-58 SERIES

304 SS BODY CONSTRUCTION
3X 4 DEG. FRONT 1/8" FNPT PORTS
1/2" FNPT INLET PORT
1.5" O.D. X 4" L
WEIGHT
40-85 GPM FLOW RANGE

BOTH SIZES SHOWN IN IMAGES BELOW.

OVERVIEW

A NEEDED TOOL FOR LETTING JETTING EQUIPMENT DO BIG WORK. LARGER DIAMETER STORM AND SANITARY LINES ARE WHAT THIS NOZZLE WAS DESIGNED TO TACKLE. JET PATTERNS DESIGNED TO PRODUCE AN EFFECTIVE FOOTPRINT. FEATURES LIKE REPLACEABLE COMPONENTS (SKID FEET & UPPER CAGES), THE 4140 HEAT-TREATED CONSTRUCTION KEEPS THIS NOZZLE AROUND FOR YEARS TO COME. THESE ALSO HAVE PROVISIONS FOR PAIRING THEM UP FOR ADDED CLEANING POWER. A FLOW DIVIDER KIT WITH BALL SOCKET JOINTS LET OPERATORS ADJUST FLOW AND PAIR THIS NOZZLE UP.

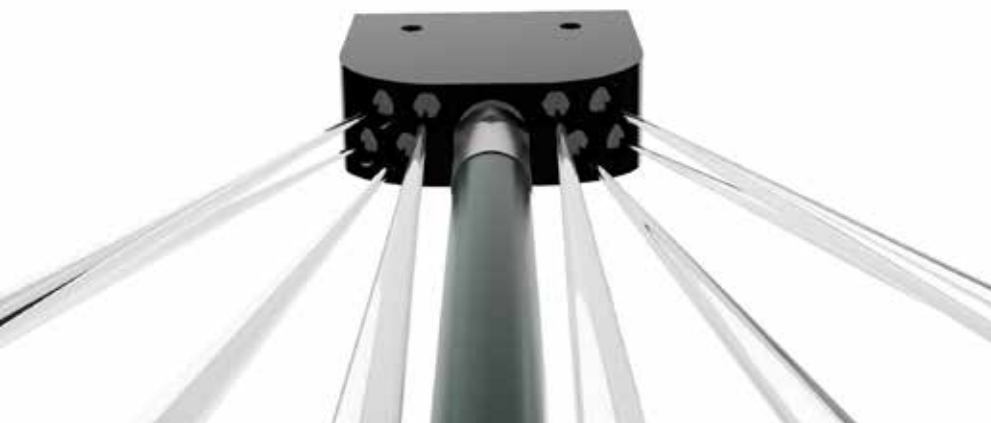

CHISEL NOZZLES

MAINLINE
SANITARY
SERVICE
STOPPAGES
STORMWATER

TECHNICAL INFO

3007-41 SERIES
CARBON STEEL CONSTRUCTION
0 DEG. FRONT M6 PORT
15 DEG. FRONT M6 PORTS (X3)
15 DEG. REAR M6 PORTS (X6)
1/2" FNPT INLET PORT
1.5" O.D. X 4" L
14-25 GPM FLOW RANGE

3007-49 SERIES
CARBON STEEL CONSTRUCTION
0 DEG. FRONT M6 PORT
15 DEG. FRONT 1/16" FNPT PORTS (X3)
15 DEG. REAR 1/8" FNPT PORTS (X6)
3/4" FNPT INLET PORT
2.3" O.D. X 4.5" L
30-50 GPM FLOW RANGE

3007-42 SERIES
CARBON STEEL CONSTRUCTION
0 DEG. FRONT 1/8" FNPT PORT
15 DEG. FRONT 1/8" FNPT PORTS (X3)
15 DEG. REAR 1/8" FNPT PORTS (X6)
1" FNPT INLET PORT
3" O.D. X 5" L
30-85 GPM FLOW RANGE



OVERVIEW

AN INDUSTRY CLASSIC MADE WITH AMERICAN STEEL. THIS CHISEL NOZZLE, AVAILABLE IN THREE SIZES, IS READY TO HELP YOU TACKLE ANY BLOCKAGE YOU COME UP AGAINST. EQUIPPED WITH FOUR FORWARD-FACING JETS TO TEAR UP ORGANIC BLOCKAGES. GREASE BUILD UPS ARE NO PROBLEM FOR THIS NOZZLE AND OUR CHISEL WILL HAVE YOU BACK AT FULL FLOW IN NO TIME!

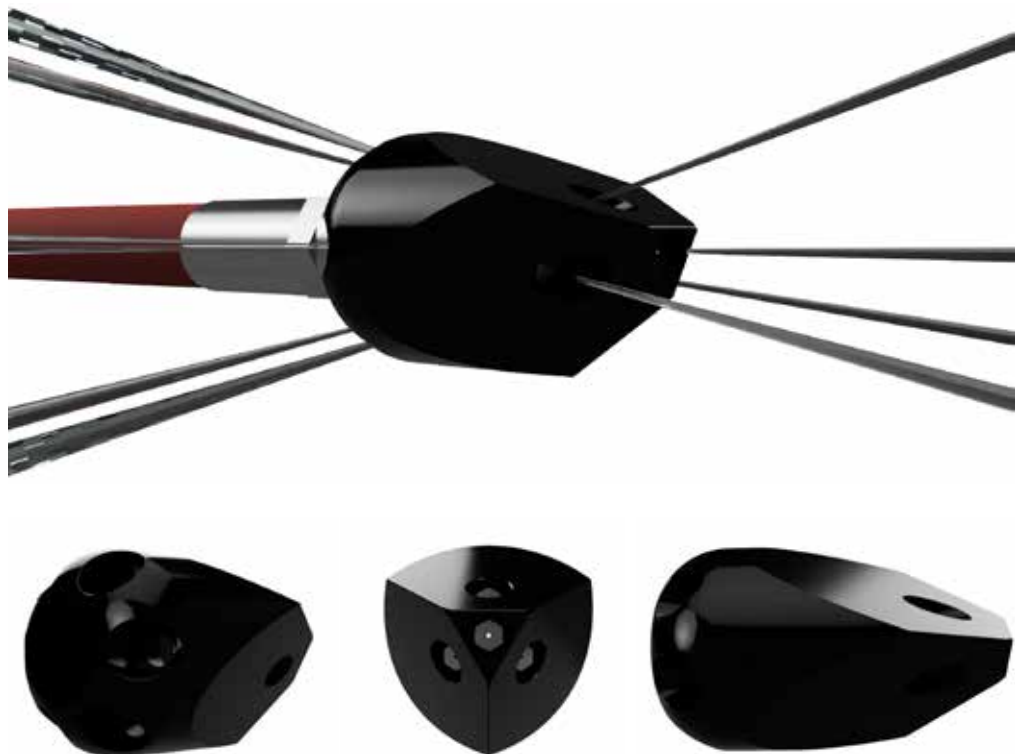

SAND HOG NOZZLE

MAINLINE
SANITARY
STOPPAGES
STORMWATER
PRODUCTION CLEANING

TECHNICAL INFO

3007-138 SERIES

ALUMINUM BODY CONSTRUCTION
0 DEGREE FRONT 1/8" FNPT PORT
15 DEGREE REAR 1/8" FNPT PORTS (X8)
3/4" FNPT INLET PORT
2.3" O.D. X 6" L
3# WEIGHT
14-50 GPM FLOW RANGE

3007-148 SERIES

ALUMINUM BODY CONSTRUCTION
0 DEGREE FRONT 1/8" FNPT PORT
15 DEGREE REAR 1/8" FNPT PORTS (X8)
1" FNPT INLET PORT
3" O.D. X 9" L
5# WEIGHT
30-85 GPM FLOW RANGE

OVERVIEW

AN ALUMINUM BODY SETS THIS NOZZLE APART FROM THE REST. THANKS TO ITS LIGHTWEIGHT THE APPLICATION FOR THIS NOZZLE IS WIDE SPREAD AND CAN CLEAN WEAK LINES, LINES FULL WITH SAND, LINES ON A STEEP GRADE OR JUST GENERAL SANITARY CLEANING. OUR USERS ON THE EAST AND WEST COAST DEALING WITH SAND HAVE FALLEN IN LOVE WITH THIS NOZZLE. WITH FOUR DIFFERENT INLETS AVAILABLE AT 1", 3/4", 1/2" AND 3/8" THERE IS A SAND HOG THAT WILL PAIR PERFECTLY WITH YOUR JETTER.



HOT DAWG NOZZLE

MAINLINE
SANITARY
STORMWATER

TECHNICAL INFO

3007-143 SERIES

CARBON STEEL BODY
0 DEG. FRONT 1/16" FNPT PORT
15 DEG REAR 1/16" FNPT PORTS (X6)
3/4" FNPT INLET PORT
2.3" O.D. X 9" L
14-50 GPM FLOW RANGE
10# WEIGHT

3007-147 SERIES

304 SS BODY CONSTRUCTION
3X 4 DEG. FRONT 1/8" FNPT PORTS
15 DEG REAR 1/8" FNPT PORTS (X6)
1" FNPT INLET PORT
3" O.D. X 9" L
40-85 GPM FLOW RANGE
14# WEIGHT



OVERVIEW

THE HOT DAWG HAS A DESIGN BASED ON INDUSTRY-FAVORITE ELEMENTS THAT MAKE THIS A MUST HAVE FOR EVERY OPERATOR. IT PRODUCES A LARGE AMOUNT OF THRUST COUPLED WITH PLENTY OF WEIGHT. LOW-ANGLED THRUST JETS DON'T LET THIS NOZZLE FLY UNDER ANY CIRCUMSTANCES. CONSTRUCTED FROM HEAT-TREATED ALLOY STEEL TO ENSURE A LONG CAREER ON ANY UNIT. IT ALSO FEATURES REPLACEABLE INSERTS MAKE THIS CONFIGURABLE FOR YOUR WATER SYSTEM.



BULKHEAD NOZZLE

MAINLINE
STORMWATER
FLOOR CLEANER

TECHNICAL INFO

3007-249 SERIES
CARB

3007-250 SERIES
304 SS BODY CONSTRUCTION
3X

OVERVIEW

REGARDLESS OF PIPE DIAMETER, THE RED DAWG BULKHEAD IS UP FOR THE CHALLENGE. THIS MAMMOUTH OF A NOZZLE FEATURES 14 JETS GIVING ULTIMATE CLEANING POWER IN EVEN THE LARGEST OF PIPES. WE OFFER TWO SEPARATE VERSIONS OF THE BULKHEAD, THAT ALLOW OUR 3/4" JETTERS TO RUN A SIMILAR NOZZLE THAT HAS 8 JETS ON THE REAR. ADDITIONAL WEIGHTS ARE AVAILABLE TO KEEP THIS NOZZLE IN LARGER, ROUNDED PIPE. WHAT SETS THIS FLOOR CLEANER APART FROM THE COMPETITION IS A LACK OF WELDMENTS WHICH MEANS EACH PIECE OF THIS NOZZLE IS REPLACABLE IF IT WERE TO WEARDOWN.

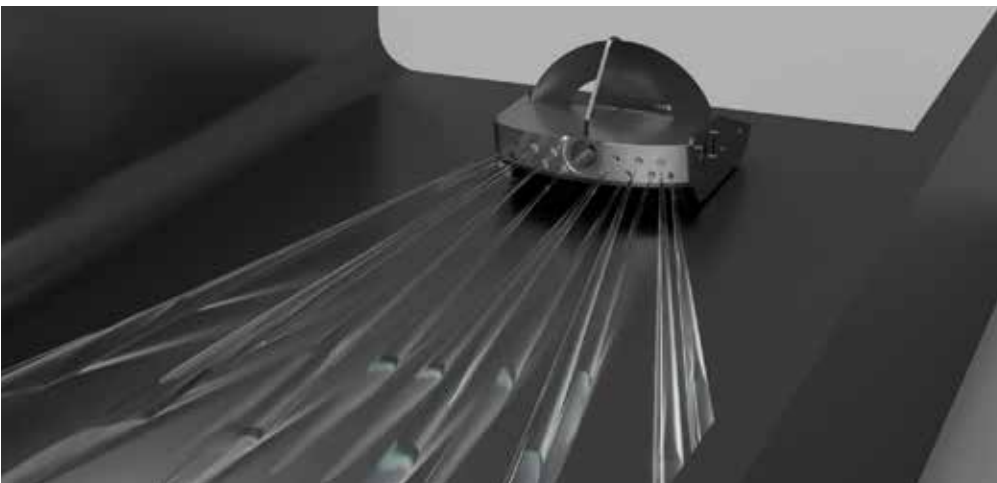

TRIPLE TAP NOZZLE

MAINLINE
SANITARY
STORMWATER

TECHNICAL INFO

3007-143 SERIES

CARBON STEEL BODY

0 DEG. FRONT 1/16" FNPT PORT

15 DEG REAR 1/16" FNPT PORTS (X6)

3/4" FNPT INLET PORT

2.3" O.D. X 9" L

14-50 GPM FLOW RANGE

10# WEIGHT

3007-147 SERIES

304 SS BODY CONSTRUCTION

3X 4 DEG. FRONT 1/8" FNPT PORTS

15 DEG REAR 1/8" FNPT PORTS (X6)

1" FNPT INLET PORT

3" O.D. X 9" L

40-85 GPM FLOW RANGE

14# WEIGHT



OVERVIEW

THE RED DAWG TRIPLE TAP WORKS VERY SIMILARLY TO THE LATERAL KNIFE BUT PROVIDES MORE OF A DIRECT BLAST TOWARDS THE CENTER OF THE LINE WITH THREE CENTERED EST JETS. THESE EST JETS PROVIDE A POWERFUL BLAST TOWARDS WHATEVER BLOCKAGE YOU ARE LOOKING TO CLEAR INSIDE OF A LATERAL OR SMALL DIAMETER LINE. AVAILABLE FOR 3/4" OR 1/2" SYSTEMS, THIS LINE IS IDEAL FOR ANY LATERAL OR SERVICE LINE GIVING YOU TROUBLE!

LOW PRO NOZZLE

MAINLINE
SANITARY
SERVICE



OVERVIEW

THIS IS A FANTASTIC NOZZLE FOR CLEANOUT & STOPPAGE WORK. THE THREE FORWARD JETS ALLOW THIS TOOL TO WORK AT ANY AND ALL OBSTACLES. THE LOW-PROFILE FEATURES ENSURE THAT HANG-UPS AND ELBOWS ARE NOT AN ISSUE. THE SIX-REAR JETS ARE ANGLED AT 25 DEG TO ENSURE CLEAN WALLS, AND REPLACEABLE WHEN NEEDED. TEST THIS FANTASTIC TOOL FOR YOUR LATERAL CLEANING.

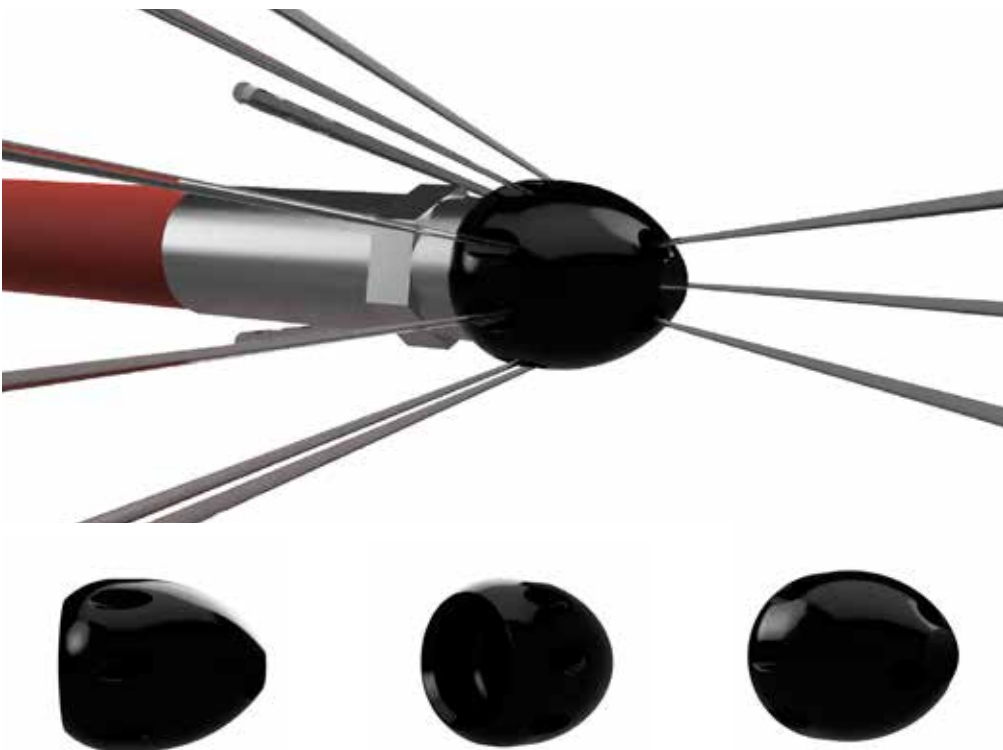

TECHNICAL INFO

71 SERIES (1/2" BODY)

CARBON STEEL BODY
10 DEG. FRONT M6 PORTS (X3)
30 DEG. REAR M6 PORTS (X6)
1/2" FNPT INLET PORT
1.13" O.D. X 1.5" L
<1# WEIGHT
14-25 GPM FLOW RANGE

72 SERIES (3/4" BODY)

CARBON STEEL BODY
10 DEG. FRONT M6 PORTS (X3)
30 DEG. REAR M6 PORTS (X6)
3/4" FNPT INLET PORT
1.5" O.D. X 2" L
<1# WEIGHT
40-50 GPM FLOW RANGE

73 SERIES (1" BODY)

CARBON STEEL BODY
10 DEG. FRONT M6 PORTS (X3)
30 DEG. REAR M6 PORTS (X6)
1" FNPT INLET PORT
1.75" O.D. X 2" L
<1# WEIGHT
60-85 GPM FLOW RANGE

BUTTON SERIES

MAINLINE
SANITARY
SERVICE
STOPPAGES
STORMWATER

TECHNICAL INFO

323-12 STANDARD BUTTON SERIES

(3/4" HOSE)

CARBON STEEL BODY CONSTRUCTION
0 DEG. FRONT 1/8" FNPT PORT
1.8" O.D. X 1.8" L
<1# WEIGHT
14-60 GPM FLOW RANGE

323-12.AXE AXE BUTTON SERIES

(3/4" HOSE)

CARBON STEEL BODY CONSTRUCTION
0 DEG. FRONT 1/8" FNPT PORT
1.8" O.D. X 1.8" L
<1# WEIGHT
14-60 GPM FLOW RANGE

323-12.SUP SUPER BUTTON SERIES

(3/4" HOSE)

CARBON STEEL BODY CONSTRUCTION
0 DEG. FRONT 1/8" FNPT PORT
1.8" O.D. X 1.8" L
<1# WEIGHT
14-60 GPM FLOW RANGE

323-12.ICE ICE BUTTON SERIES

(3/4" HOSE)

CARBON STEEL BODY CONSTRUCTION
0 DEG. FRONT 1/8" FNPT PORT
1.8" O.D. X 1.8" L
<1# WEIGHT
14-60 GPM FLOW RANGE



OVERVIEW

INDUSTRY STANDARD FEATURES MAKE THESE AN EASY CHOICE. LOW-COST AND VERY SMALL FORM FACTOR MAKE THIS A MUST HAVE FOR ANY JETTER. FEATURING 6-REAR 30 DEGREE JETS AND AN OPTIONAL PENETRATOR FRONT JET, CARBON STEEL CONSTRUCTION ENSURE THESE LAST LONGER THAN THE STAINLESS COMPETITION. AVAILABLE IN FLOWS FROM 18 GPM UP TO 60 GPM.

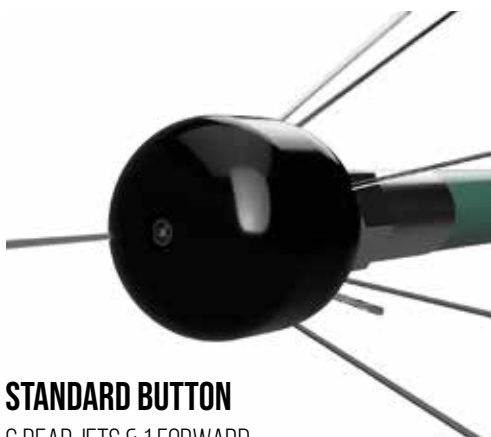

STANDARD BUTTON

6 REAR JETS & 1 FORWARD

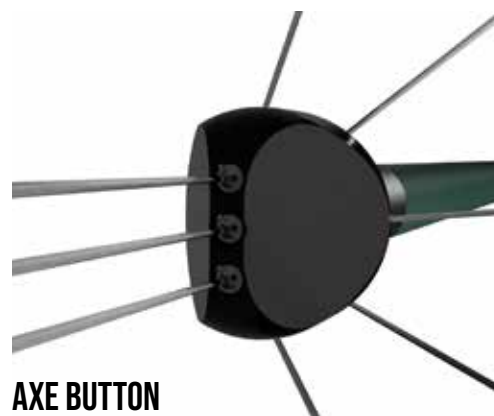

AXE BUTTON

6 REAR JETS & 3 FORWARD JETS INLINE

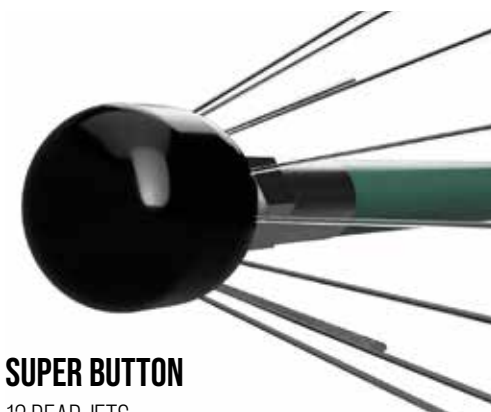

SUPER BUTTON

12 REAR JETS

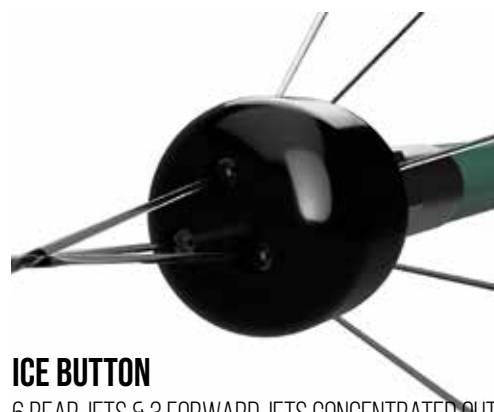

ICE BUTTON

6 REAR JETS & 3 FORWARD JETS CONCENTRATED OUT FRONT OF THE NOZZLE

ALUMINUM SAND NOZZLE

MAINLINE
STOPPAGES
STORMWATER



OVERVIEW

INDUSTRY STANDARD FEATURES MAKE THESE AN EASY CHOICE. LOW-COST AND VERY SMALL FORM FACTOR MAKE THIS A MUST HAVE FOR ANY JETTER. FEATURING FIVE-REAR 30 DEGREE JETS AND AN OPTIONAL PENETRATOR FRONT JET, CARBON STEEL CONSTRUCTION ENSURE THESE LAST LONGER THAN THE STAINLESS COMPETITION. AVAILABLE IN FLOWS FROM 18 GPM UP TO 80 GPM.

TECHNICAL INFO

3007-322 SERIES (1" OR 3/4" HOSE)
ALUMINUM BODY CONSTRUCTION
0 DEG. FRONT 1/8" FNPT PORT
25 DEG. REAR 1/8" FNPT PORTS
4" O.D. X 5" L
5# WEIGHT
30-85 GPM FLOW RANGE

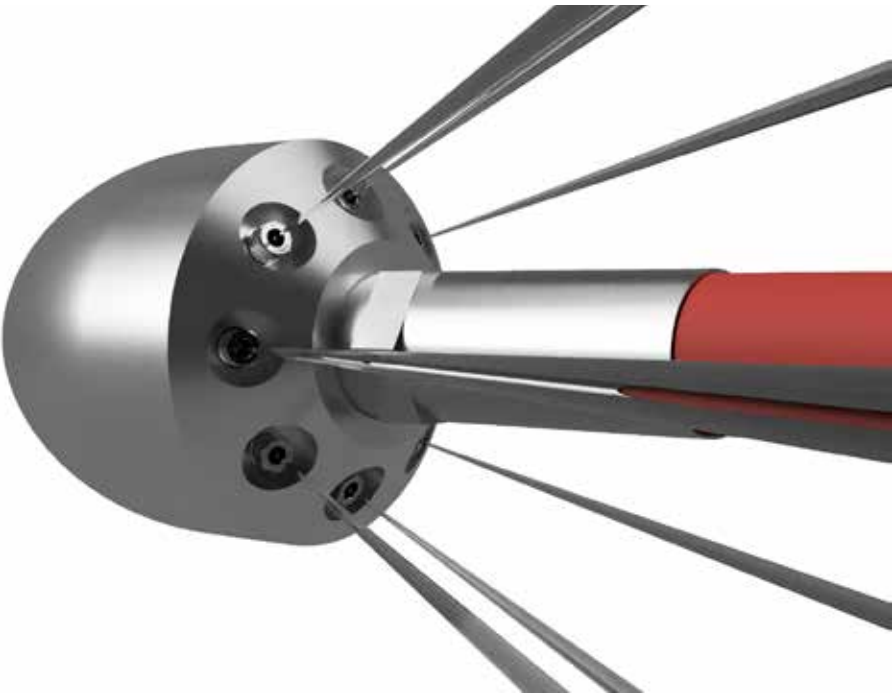

KRAKEN ROOT CUTTER KIT

LATERAL STOPPAGES

TECHNICAL INFO

311-16 SERIES (1" & 3/4" HOSE)

CARBON STEEL BODY CONSTRUCTION

0 DEG. FRONT 1/8" FNPT PORT

1.8" O.D. X 1.8" L

13# WEIGHT

40-60 GPM FLOW RANGE



OVERVIEW

THE KRAKEN IS A NEW PLATFORM FOR ROOT CUTTING. WE BEEFED UP THE MAIN SPINDLE SO IT WILL NEVER BEND UNDER ANY CIRCUMSTANCES. IF THE ROOT KNIVES EVER GET TORN UP (3 SIZES AVAILABLE), IT'S A SIMPLE SWAP OUT WITH 1/4-20 HARDWARE. WE TOOK THE COMPLEXITY OUT OF ROOT CUTTER SETUPS & MAINTENANCE. DESIGNED TO WORK FOR LINES FROM 6 INCH UP TO 12 INCH.



HYDRO X TIPS

HYDRO-EXCAVATION
SURFACE CLEANING
JOB CLEANUP



OVERVIEW

THESE HYDRO X SERIES NOZZLES ARE BUILT TO LAST. THE BODIES ARE MACHINED FROM BILLET STAINLESS STEEL. THERE ARE TWO AVAILABLE ORIENTATIONS ARE SINGLE AND THREE JET. BOTH BODIES FEATURE OUR VERY EFFICIENT EST INSERTS. BOTH PACK A SERIOUS PUNCH BECAUSE OF THEM.

TECHNICAL INFO

200-1 SERIES (SINGLE JET BODY)
STAINLESS STEEL BODY CONSTRUCTION
0 DEG. FRONT 1/8" FNPT PORT
1/2" FNPT INLET PORT
1.5" O.D. X 4" L
1-10.5 GPM FLOW RANGE
3200 PSI MAX PRESSURE

200-3 SERIES (TRIPLE JET BODY)
STAINLESS STEEL BODY CONSTRUCTION
4 DEG. FRONT 1/8" FNPT PORTS (X3)
1/2" FNPT INLET PORT
1.5" O.D. X 4" L
1-25 GPM FLOW RANGE
3200 PSI MAX PRESSURE



HOSE PROTECTION & ACCESSORIES



Upper Manhole Roller

Protect your jet hose with this aluminum roller.
P/N: 8401-1401



Easement Roller

Protects your hose around corners.
P/N: LMER-1



Easement Stake Roller

Helps when jetting stormwater drains.
P/N: SSR-5



Tiger Tail

Protect your hose from sharp transitions above and below ground level.
2" P/N: 3007-7001
3" P/N: 3007-7000



Little Jake Rhino Hammer

Incorporates a hook and 8# ledge into one factastic tool. Yellow for high visibility also.
P/N: 3029-2429



Mary A Rhino Hammer

Incorporates a hook and 12# ledge into one factastic tool. Yellow for high visibility also.
P/N: 3029-2428



Manhole Hook, 36"

Forged from hex steel stock and heat-treated. Made to last and always be useful.
P/N: 3008-0511



Hydrant Wrench

Zinc plated construction makes this a long-lasting addition to your arsenal.
P/N: 3007-8001

JET HOSE & HOSE ENDS



Jet Hose Assemblies

Call for new hose roll assemblies from multiple different hose manufacturers. We carry the leading lines and more economical.

Hose Menders

Address damaged sections of your jet hose without cutting too much hose off. These should be installed sparingly and according to manufacturer specifications.

Male NPT Hose Ends

Cut your jet hose back and install the correct fitting on your hose. Not following the manufacturer recommended guidelines puts operators at risk.

FITTINGS, QUICK COUPLINGS & RECEIVERS



**FMNPT x
NPT
Swivel**

Galvanized
Steel
5404 Series
1" to 3/4"
3/4" to 1/2"
1/2" to 3/8"



**Hex
Adapter**

Galvanized
Steel
5406 Series
1" x 1"
1" x 3/4"
3/4" x 3/4"
3/4" x 1/2"
1/2" x 1/2"



**Reducer
Bushing**

Galvanized
Steel
RB16-12 &
RB12-8



**Hex
Coupler**

Galvanized
Steel
1405 Series
1" x 1"
1" x 3/4"
3/4" x 3/4"
3/4" x 1/2"
1/2" x 1/2"



**Hex
Bushing**

Galvanized
Steel
5000 Series
1" to 3/4"
3/4" to 1/2"
1/2" to 3/8"

HANDGUNS AND HYDRO-X



High-Flow Washdown

Flows up at 25 GPM with a variable pattern handle/grip on main tube.

10 @ 3000 P/N: 3023-5008

25 @ 850 P/N: 3023-5006



43H High-Flow Washdown

Great form factor, works on any jetter. Rated at 850 PSI @ 20 GPM

P/N: 3023-5002



RipSaw Rotating Nozzle

The RipSaw Rotating Turbo nozzle is specifically designed and engineered for the rugged Hydro-Excavation industry. It's cone shaped flow pattern is ideal for potholing applications. Save water and get more digging done with the RipSaw.

6.0, P/N: 3007-5903

12.0, P/N: 3007-5900



SwitchBlade

The Switchblade™ nozzle is designed and engineered for the rugged Hydro-Excavation industry. These heavy-duty, high-impact nozzles allow you to cut through dirt faster while using dramatically less water. The flow-straightened insert pills improve stream quality over the competition.

(Left) Switchblade Quad, P/N: 3007-1779 - Four Jet

(Middle) Switchblade Dual, P/N: 3007-2035 - Two Jet

(Right) Switchblade Ace, P/N: 3007-2036 - Single Jet

SWIVELS AND ACCESSORIES

Leader Hose

Constructed to take the stress of the most worked end of the hose. Save your main jet hose from unneeded abuse by utilizing a leader hose. It also doubles as a marker for when the hose has arrived back at the entry point. Longer lengths available also.

1/2" x 10' P/N: 3009-4537

3/4" x 10' P/N: 3009-4522

1" x 10' P/N: 3009-4528



Forward Cage Skids

Extend the life of your nozzle with this skid.

3/4" P/N: 3009-FS75

1" P/N: 3009-FS100



Roller Skids

Best for long runs when cleaning. Inquire for specific hose and line sizes from 6" to 15".



Tube Skids

Keep your operators safe.

1/2" P/N: TSE-1/2

3/4" P/N: TSE-3/4

1" P/N: TSE-1

Straight Swivel

SS Super Swivel, Straight

FNPT x MNPT

P/N: 3020-0119

P/N: 3020-0054



90 Degree Swivel

SS 90 deg. swivel rated for 3,000 PSI. Rebuildable as needed.

P/N: 3020-2000



Lateral Cart

This accessory is a must for smaller cleanout & lateral lines. It features hose capacities up to 350' of 1/2" jet hose. This reel assembly normally comes with 150' of 1/2" high-pressure jet hose. This can be adapted or built with 3/8" hose assemblies if needed.

P/N: 8000-0127 (with 150' of 1/2" hose)

Red Dawg can help tackle lots of drainage issues



OLD BRICK LINES



CONCRETE



STORM DRAINS



MANHOLE MAINTENANCE



BOX CULVERTS



ROOTS, ROOTS & MORE ROOTS

ABOUT RED DAWG

WE ARE A SMALL TEAM THAT IS VERY PASSIONATE ABOUT SEWER CLEANING TOOLS. OUR GOAL EVERYDAY IS TO PRODUCE THE BEST WE CAN WITH THE KNOWLEDGE WE HAVE ACQUIRED ALONG THE WAY. EVERY DAY WE GET BETTER AT WHAT WE DO AND TRANSLATE THAT TO SUPERIOR PRODUCTS.

OUR GUARANTEE

TEXAS UNDERGROUND, INC. (TUI) OFFERS A LIMITED LIFETIME WARRANTY ON TOOLS AND ITEMS MANUFACTURED BY TUI. THIS WARRANTY APPLIES AGAINST MANUFACTURING DEFECTS. LIMITED WARRANTIES EXIST ON ALL BODIES, INSERTS, AND COMPONENTS. TUI WILL NOT WARRANTY AGAINST LOSS, FAILURE AND/OR DAMAGE DUE TO: IMPROPER SET-UP, IMPROPER ASSEMBLY, ABNORMAL WEAR, IMPROPER USE, USE OUTSIDE THE DESIGN PARAMETERS OF THESE TOOLS, UNAUTHORIZED MODIFICATION OF THESE TOOLS, OR FAILURE TO PERFORM RECOMMENDED MAINTENANCE ON SAID TOOLS. TUI WARRANTS THE QUALITY OF ALL TOOLS SUPPLIED FOR THE DURATION OF 12 MONTHS FROM DATE OF PURCHASE.

MANUFACTURED BY:
TEXAS UNDERGROUND, INC.
1617 GARDEN ROAD
PEARLAND, TX 77581

800.373.1318

SALES@REDDAWGNOZZLES.COM